

*Freedom,
the way you like it!*



On the road at home with Webasto comfort solutions!

www.webasto-outdoors.com



Travel in comfort with Webasto

Innovative comfort solutions with great ease of use

Our goal is to make sure our customers travel in comfort. This includes a perfectly warm cabin in cold nights as well as hot water for long showers. Webasto does not just provide products, but complete comfort solutions. We consider all interactions in between product, end user and the vehicle where our product is installed, in order to offer our customers the best possible option.

With easy operation, space saving installation, increased autonomy, clever usage of energy and fuel on board, Webasto offers much more than high-performing diesel heaters.

Our product portfolio ranges from heating systems over diesel cookers to fuel cell power supply. With our Webasto heating systems in particular we have set standards of comfort for over 50 years.

Millions of satisfied customers worldwide rely on Webasto's long experience and professional expertise.

Your Webasto Recreational Vehicle Team

Innovation dedicated to the Recreational Vehicle Market!



1985
Webasto offers heaters from other markets to the RV market

2000
Webasto goes international in the RV market

2002
Webasto is first in underfloor heating applications

2006
Webasto develops the Dual Top: a combined air and water heater

2008
Webasto introduces the Dual Top with electrical coil

1990
Webasto supplies RV dedicated applications to the RV market

2001
Webasto incorporates special accessories for RVs

2004
Webasto offers a diesel cooking solution for RVs

2007
Webasto introduces first gas free solution to the RV market

2009
Heaters with integrated Automatic Altitude Adjustment (Evo)



Webasto Product Portfolio for Recreational Vehicles

Air Heater & Water Heaters:



Air Top air heaters

Thanks to a unique regulation technology, Webasto air heaters provide precise and constant cabin temperature control at any altitude – without any undesirable noise.



Thermo Top water heaters

The water heaters are integrated in the coolant circuit of the vehicle engine, ensuring that the cabin of the vehicle is also properly heated. They also preheat the engine for reliable starting.

Integrated Air & Water Heaters:



Dual Top integrated air and water heaters

Dual Top is a multimode operation system to provide heating and hot water in all seasons. It is designed to be installed outside the vehicle for more storage space and personal comfort.

Diesel Cooker:



Diesel Cooker X 100

The perfect solution for those who require a smart gas free solution. The combustion of the diesel fuel creates heat which is conducted to and evenly distributed on a CERAN® cooking plate.

Compressor Fridges:



Isotherm Compressor fridges

Special design refrigeration solutions offered for customised projects. Appliances can also be integrated into vehicle's furniture design. They include special power-saving patents.

Fuel Cell Power Supply:



EFOY fuel cells

The EFOY fuel cell provides additional energy on board. Pure methanol is used to produce energy capacities varying from 600 Wh up to 2,200 Wh a day.



Benefit from increased autonomy!

Webasto enables RV enthusiasts to enjoy a new way of motor home holidays. Most of today's RV engines are diesel powered. So why burden oneself with the dependence on an additional fuel source?

With a diesel powered heater and a 70 litre vehicle fuel tank, users can easily enjoy several days of autonomy. Refilling diesel is no problem worldwide, as it is a standard everywhere. Tedious work with gas adapters during holidays abroad is a thing of the past. An additional fuel cell combined with a 5 litres methanol canister offers increased electrical autonomy, similar to 5-6 standard batteries.

- More space inside
- Less weight
- Increased fuel autonomy
- Increased electrical autonomy
- Perfect climate on board
- Universal solutions across borders

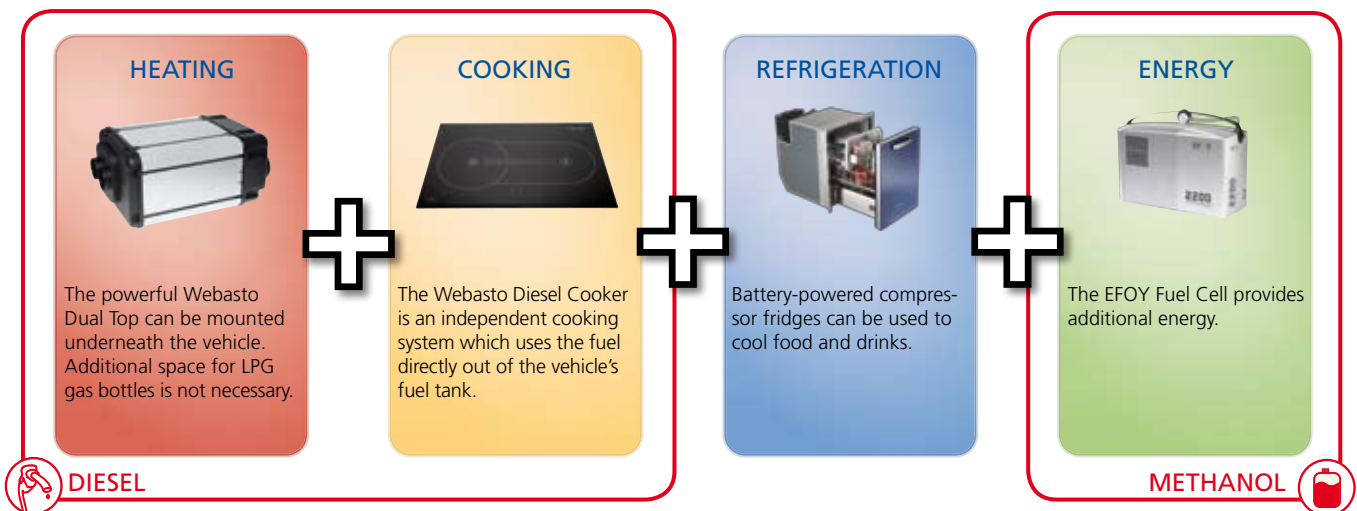

Webasto Air Top: Air heater solutions

*Cosy comfort with Webasto diesel-fueled air heaters.
Compact, powerful and easy to handle.*

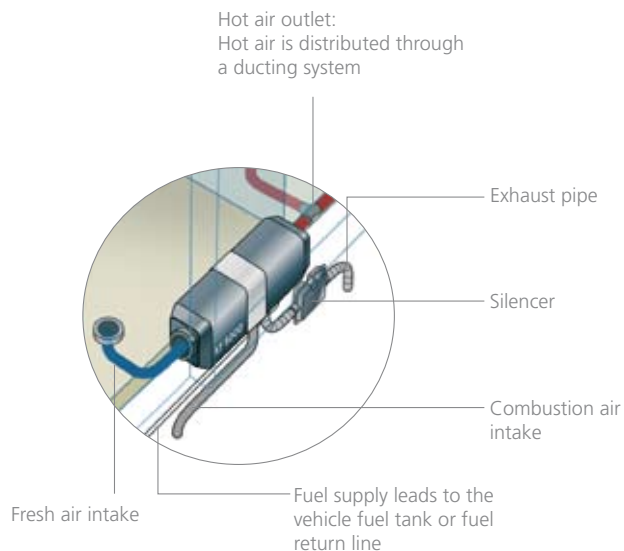
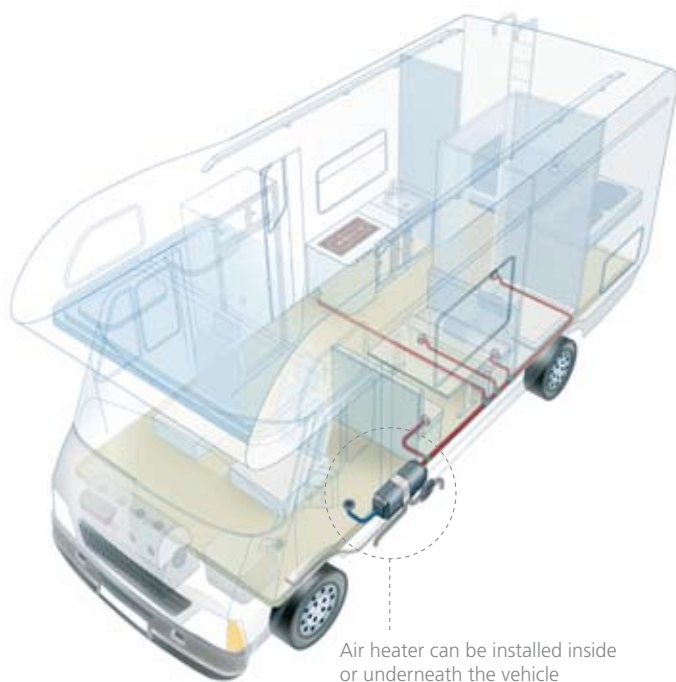

Technical specifications:

	Air Top 2000 ST	Air Top 3900 Evo	Air Top 5500 Evo
Heating power (kW)	0.9 - 2.0	1.5 - 3.5 (3.9)*	1.5 - 5.0 (5.5)*
Fuel	Diesel	Diesel	Diesel
Fuel consumption (l/h)	0.13 - 0.27	0.18 - 0.42 (0.47)*	0.18 - 0.60 (0.66)*
Rated voltage (V)	12	12	12
Operating voltage range (V)	10 - 15	9 - 16	9 - 16
Rated input (W)	14 - 29	15 - 40 (55)*	15 - 95 (130)*
Air flow (m ³ /h)	93	132 (139)*	200 (220)*
Dimensions L x W x H (mm)	311 x 120 x 121	423 x 148 x 162	423 x 148 x 162
Weight (kg)	2.6	5.9	5.9

*Boost mode



Air Top control elements:

■ Evo Contol: 3 heaters in 1!

Newly developed control for the new Air Top Evo generation. Freedom to choose in between several modes: normal heating, fast heating (Boost), energy-saving heating (ECO) and ventilation.



Automatic Altitude Adjustment (AAA) for great performance in heights.

■ Air Top Digital Timer

Easy programming of the air heater. This timer offers an integrated clock, temperature selection and three different week programs.



■ Standard Control

Selection of the desired temperature by turning the knob.



Webasto air heaters are ideal as primary or secondary heaters on board of recreational vehicles.

Stepless regulation of the heaters allows a stable cosy warmth inside the cabin, while assuring the best combustion and lowest consumption at the same time. The integrated altitude sensor (Evo series) guarantees that even with low air pressure and lower oxygen content at high altitude, the heaters generate an optimum heat output at all times.

The heaters are easy to install either inside or outside the vehicle. Due to their compact design, a suitable place can be found in all types of vehicles.

Product highlights:

- Short heat-up times
- Stepless power modulation to maintain constant cabin temperature
- Automatic altitude adjustment (AAA) as standard feature (Evo)
- Perfect secondary heater retrofit option
- Multimode operation including ECO and Boost functions

Webasto Thermo Top & Thermo 90: Water heater solutions

Heated cabin and pre-heated engine with Webasto water heaters.

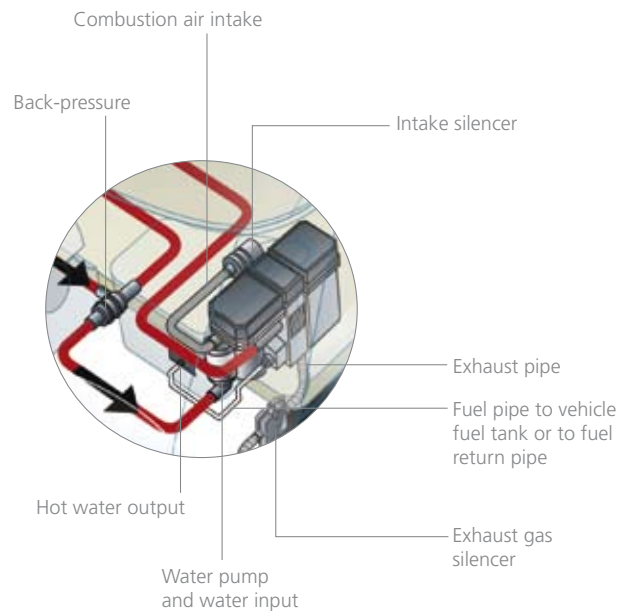

Technical Specifications:

	Thermo Top C Motorcaravan	Thermo 90 ST
Heating power (kW)	2.5 - 5.2	1.8 - 7.6 (9.1)*
Fuel	Diesel	Diesel
Fuel consumption (l/h)	0.30 - 0.61	0.22 - 1.04 (1.27)*
Rated voltage (V)	12	12
Operating voltage range (V)	10.5 - 15	10 - 15
Rated power consumption (W)	18 - 42	37 - 83 (90)*
Dimensions L x W x H (mm)	214 x 106 x 168	355 x 133 x 232
Weight (kg)	2.9	4.8

*Boost Mode



Water heater control elements:

■ Thermo 90 Digital Timer

Integrated clock and timer with three different week programs.



■ Thermo Top Digital Timer

Simple digital timer for the Thermo Top C Motorcaravan to activate heating, either directly or at a pre-set time.



■ Thermo Top C Motorcaravan switch

Heating of the engine or the cabin can be activated via the switch mounted in the driver's cabin.



Webasto water heaters meet the very highest standards of intelligent heating solutions and provide a pleasant cabin climate. In large vehicles or integrated recreational vehicles with a big windscreen, the driver's cabin hardly warms up properly. Webasto has developed a special heater to deal with this: the Thermo Top C Motorcaravan.

It supplies warm air directly to the interior via the air outlets in the dash board. The system is integrated in the water circuit of the vehicle engine, ensuring that the engine starts reliably – even on cold days.

Webasto water heating systems are available in various power levels and sizes. In order to ensure that the heat in the vehicle is ideally distributed with this comprehensive solution, other heat exchangers (static or dynamic) can be incorporated in the system. If using an additional boiler, domestic hot water can be supplied, too.

Product highlights:

- Supply of heat via the air outlets in the dash board
- Quiet-running operation
- Different power levels to suit individual needs

Webasto Dual Top: Integrated heater solutions

Free and easy with Webasto Dual Top.

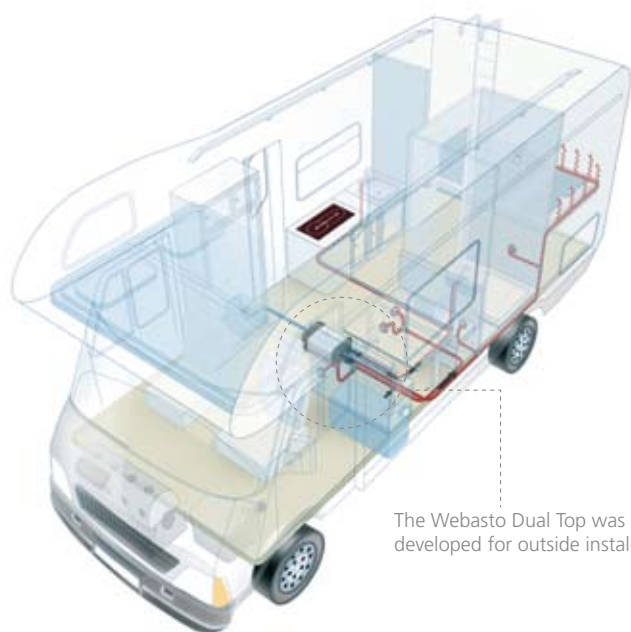

The Webasto Dual Top was specially developed for outside installation

Warm air is heated up and distributed in the vehicle via two air outlets

The domestic water boiler is connected directly to the fresh water tank

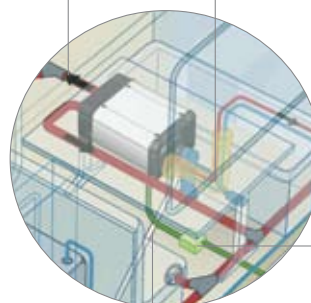

Exhaust pipe with silencer

Fuel lines lead to vehicle's tank or fuel return line

Technical Specifications:

	RHA 100	RHA 101	RHA 102
Heating power (kW)	1.5 - 6.0	1.5 - 6.0	1.5 - 6.0
Additional power with electrical coil:		0.6 - 1.2	1.0 - 2.0
Fuel	Diesel	Diesel	Diesel
Fuel consumption (l/h)	0.19 - 0.66	0.19 - 0.66	0.19 - 0.66
Rated voltage (V)	12	12	12
Operating voltage range (V)	9 - 15	9 - 15	9 - 15
Rated power consumption (W)	15 - 65	15 - 65	15 - 65
Dimensions L x W x H (mm)	530 x 352 x 256	530 x 352 x 256	530 x 352 x 256
Weight (kg)	20	21	21
Boiler capacity (l)	11	11	11
Air flow (m ³ /h)	200	200	200



Dual Top control elements:

■ Standard Control

Manual control unit with possible selection of various heating modes for domestic water and air, boiler drainage and anti-freeze functions.



■ Digital Control

Developed in cooperation with RV owners to ensure best user-friendliness, this digital control comes with Dual Top RHA 101 and RHA 102. Functions are similar to the manual control plus electric heater activation, programmable timer and remote activation and control.



A cosy, warm cabin or a long hot shower – Dual Top reliably guarantees both. The integrated air and domestic water heater uses the diesel fuel from the vehicle's tank for heating. It can be installed outside the vehicle to free storage space inside and provide more personal comfort.

In addition to the standard model with 6 kW heating capacity, the Dual Top is also available with integrated 220V electrical coil, (providing additional heat output up to 2.0 kW). The Dual Top power management system is state-of-the-art. An ingenious control system constantly monitors the inside and outside temperature and determines the necessary heat output.

The boiler, which heats up the domestic water to temperatures up to 70°C, is automatically drained at frost temperatures. The manually selectable anti-freeze mode prevents the water in the boiler from freezing.

Product highlights:

- Supply of warm air (heat output up to 8 kW) and hot water (up to 70°C)
- Designed to be installed outside the vehicle for maximum space inside
- Precise and stepless cabin temperature control
- Very fast heat-up phase
- Heating while driving allowed in all countries making hot water readily available at each stop

Webasto Diesel Cooker



Clever kitchen solution.

Technical Specifications:

Type	Diesel Cooker X 100
Cooking power (kW)	0.9 - 1.9
Fuel, Fuel consumption (l/h)	Diesel, 0.09 - 0.18
Rated voltage (V)	12
Power consumption (A)	0.3 A (max. at start-up approx. 8 A for 4 mins)
Start-up time	- 3 min.
Cooking plate temperature (°C)	up to 550
Dimensions of Ceran® hot plate L x W x H (mm)	466 x 316 x 50
Dimension of protective casing L x W x H (mm)	565 x 366 x 172 (2 cm waste air nozzle)
Weight (kg)	8 (hot plate) 1.5 (casing)



The Webasto Diesel Cooker X 100 is the perfect solution for those who require a smart solution which also works off the beaten track. The combustion of the diesel fuel creates heat which is conducted to and evenly distributed on a CERAN® cooking plate. With this solution there are no more open flames or smell of gas. Exhaust and combustion fumes are channeled directly outside the vehicle.

The one-flame cooker offers one area to cook and one to warm up meals. The Webasto Diesel Cooker can be installed in all recreational vehicles. Its optimised dimensions make it especially suitable for compact recreational vehicles.

Product highlights:

- Robust, high quality CERAN® cooking surface
- Easy to use and to clean
- Low current and fuel consumption
- Hot plate indication light
- Full functionality at high altitudes

Isotherm Compressor Fridges



Special design refrigeration solutions.



For a gas-free recreational vehicle, customers can opt for compressor fridge solutions. Through its cooperation with the Italian refrigeration specialist Indel B, Webasto is able to offer its customers special design refrigeration solutions of the highest quality. Isotherm solutions integrate numerous customisation options and attractive, patented power-saving features.

Advantages of Isotherm compressor fridges:

- High cooling capacity even in hot climates
- Fast cool down of food and drinks
- Low noise level
- Weight saving application
- High efficiency
- Ensured performance even at inclination
- Increased autonomy thanks to patented power-saving solutions
- Customised solutions for innovative layouts

EFOY Fuel Cells



Mobile energy for motor homes.

Technical Specifications:

	EFOY 600 up to EFOY 2200
Rated power (W)	25 up to 90
Charge capacity (Wh/day)	600 (50 Ah/day) up to 2,160 (180 Ah/day)
Rated voltage (V)	12
Rated current (A)	2.1 up to 7.5
Methanol consumption (l/kWh)	0.9
Noise level 7 m away dB(A)	23
Noise level 1 m away dB(A)	39
Weight (kg)	6.5 up to 7.9
Dimensions L x W x H (mm)	435 x 200 x 276
Operating temperature (°C)	-20 to +40
Recommended batteries	12 V lead batteries (lead acid or lead gel), capacity 40 to 200 Ah













The EFOY Fuel Cell represents a genuine revolution. Anyone who enjoys the great outdoors will appreciate the advantages of an electricity supply regardless of season and weather.



Unlike conventional electricity generators, EFOY is absolutely silent and maintenance-free. EFOY comes in five models and is incredibly easy to use. Producing 600, 900, 1,200, 1,600 or 2,200 Wh/day, the fuel cell generates enough electricity to meet any requirement.

Product specifications:

- Very easy, comfortable controls: automatic charge control device and digital display
- Light weight: just 7.5 kg, combined with compact dimensions for easy fitting inside vehicle
- Silent operation
- Environmentally friendly

What fits where?

Vehicle types		Motorhome Type "Camper" 	Motorhome Type "Semi-integrated"  6 m 8 m	Motorhome Type "Top bank"  6 m 8 m	Motorhome Type "Integrated"  6.5 m 8.5 m	Motorhome Type "Over 7.5 t"  > 8 m
Dual Top 						
Air Top 2000 ST 						
Air Top Evo 3900 						
Air Top Evo 5500 						
Thermo Top C Motorcaravan 						
Thermo 90 ST 						

-  Use as main heater
-  Use as additional heater alongside existing unit (e.g. LPG gas)
-  Use as additional heater or water heater

Webasto, a feel good climate – world-wide

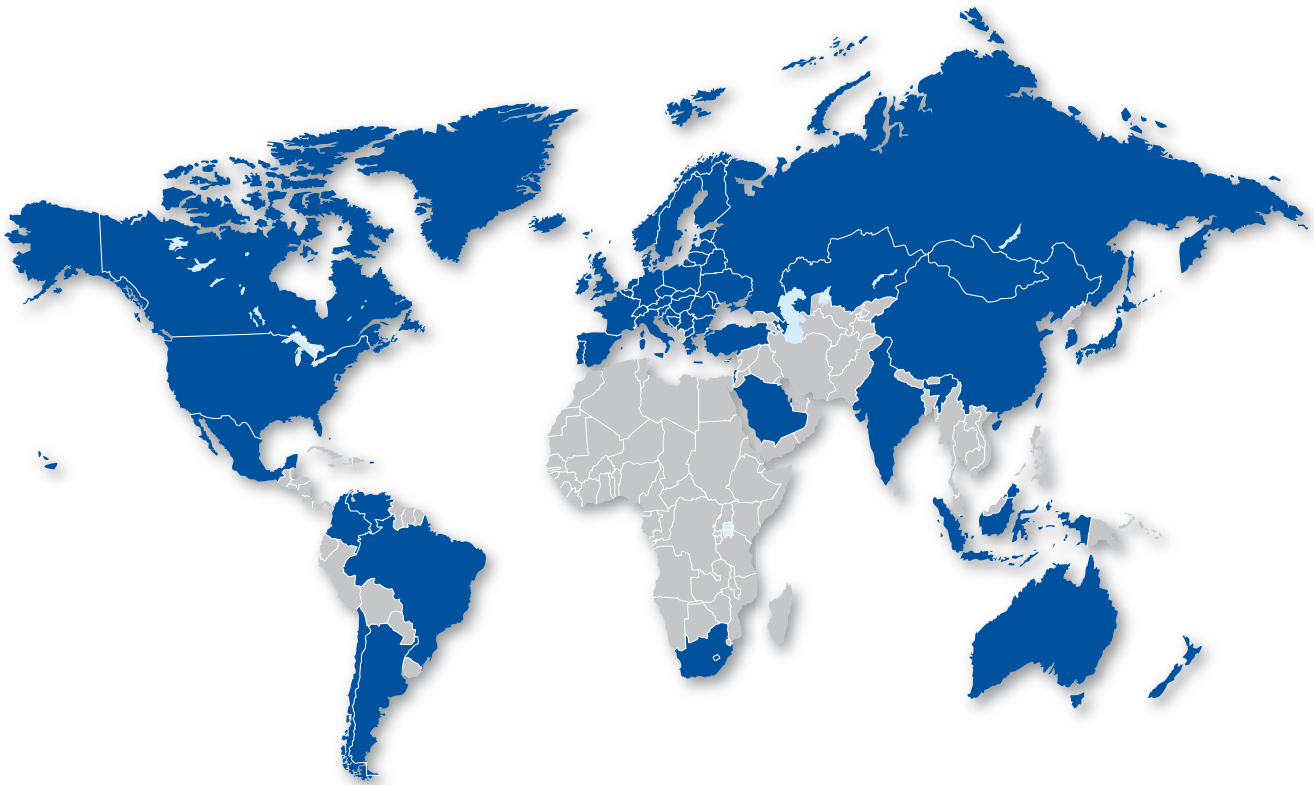

Whether OEM or aftermarket: our products improve the comfort in vehicles. With our company motto „Feel the drive“, the name Webasto stands for innovative, economic and environmentally sound heating, cooling and ventilation systems for cars, commercial vehicles, motorhomes and boats. Our success is based on our wide range of products and high quality standard. An outstanding network of dealers guarantees top quality fitting and services around the globe.

We have been setting standards in technology for over one hundred years and are now amongst the 100 biggest suppliers to the automotive industry world-wide. Webasto operates in two business units: Convertible, Roof & Body (CRB) systems as well as Global Comfort Solutions (GCS) for heating, cooling and ventilation systems.